

HAPPY BUCCANEER

LIFTING HEAVY
CARGO FOR
WORLDWIDE
TRANSPORT



BIGLIFT

HAPPY S-TYPE
HAPPY BUCCANEER
HAPPY D-TYPE
HAPPY R-TYPE
TRA-TYPE

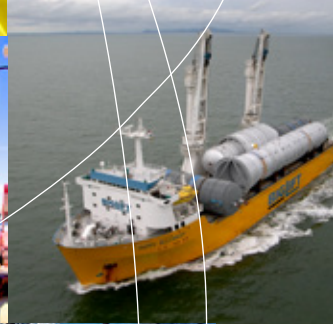

Happy Buccaneer has been one of a kind since she came into operation. She has set the industry standard for a long time. With her 2 x 700 mt Huisman crane capacity, 1400 mt combined, and her large stability she is able to utilize her full crane capacity in outreach and lifting height. The latter is still unrivalled today in the worldwide heavy lift fleet. Happy Buccaneer also offers ro-ro capacity up to 2500 mt by using the ramp and the tween deck.

Like most of the vessels of the BigLift fleet Happy Buccaneer is able to lift cargo up to full combined crane capacity without using a stability pontoon. This greatly increases safety and reliability of such critical operations.

With an impressive track record in heavy lift and special projects as offshore modules, cranes, turrets and power plant parts Happy Buccaneer has proven herself many

times during the installation of the biggest ship unloaders and wharf decks around the Australian waters.

Supported by BigLift's in house engineering and operations department Happy Buccaneer is still extending her capabilities while maintaining the high level of safety and reliability required.

BIGLIFT

HAPPY BUCCANEER

HATCH OPENINGS AND ALLOWABLE LOADS

HATCH OPENINGS

Weather deck	110.5 x 20.6 m
Tween deck	67.0 x 20.0 m

ALLOWABLE LOADS

Weather deck hatch covers	15.0 t/m ²
Tween deck hatch covers	15.0 t/m ²
Tank top	15.0 t/m ²

FLOOR SPACE

Weather deck	3,067 m ²
Tween deck	2,275 m ²
Tank top	1,344 m ²

CRANES

2 x 700 mt SWL

COMBINABLE

1400 mt

TROLLEY

25 mt SWL

PRINCIPAL DIMENSIONS

Length overall	145.89 m
Length p.p.	134.00 m
Breadth moulded	28.30 m
Summer draft	8.24 m
Draft open sailing	7.02 m

REGISTRATION

The Netherlands

CLASS

LRS X100A1 XLMC UMS
strengthened for
heavy cargoes

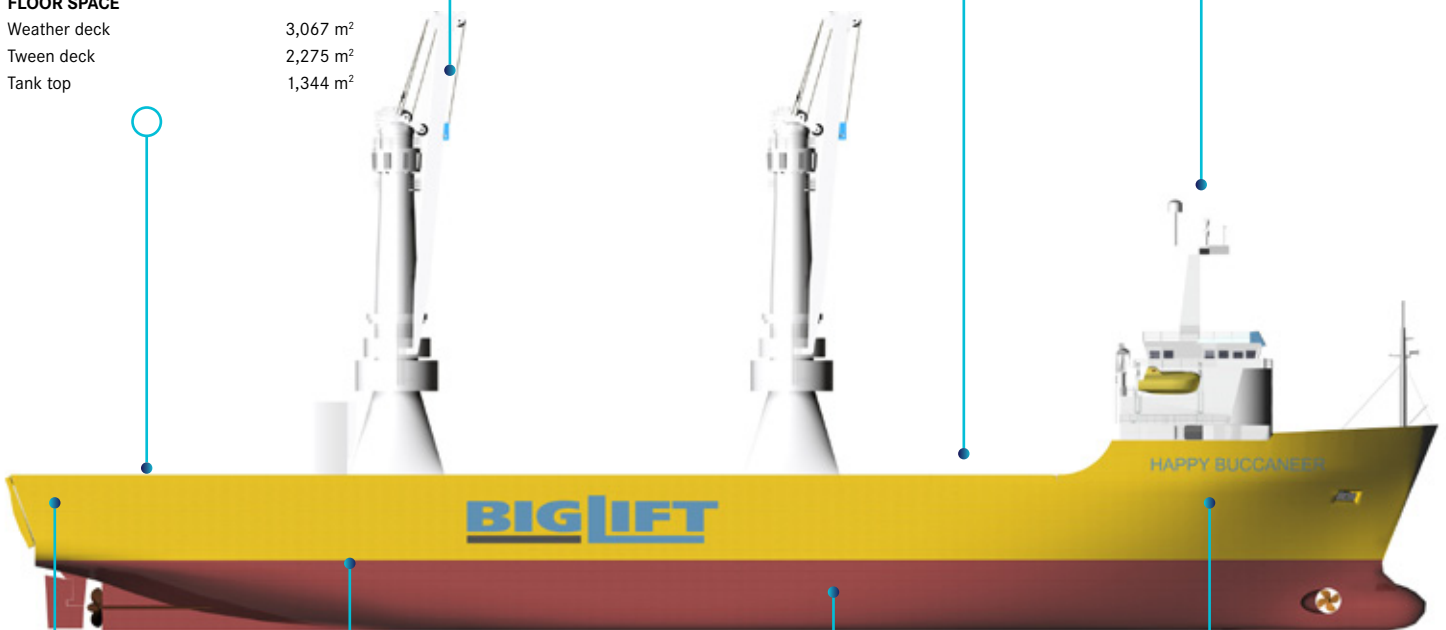

RAMP

Position	stern
Dimensions	20.3 x 7.6 m
Capacity	2,500 mt

MAIN ENGINE

Hitachi Sulzer	2 sets 3840 kW
Bowthruster	750 kW
Service speed	14.75 kn at draft 6.00 m

CAPACITY

Lower hold	7,517 m ³
Tween deck	12,391 m ³

DEADWEIGHT

At Summer (sea water) draft
13,740 mton inc. tween deck
hatch covers, pillars

HAPPY BUCCANEER

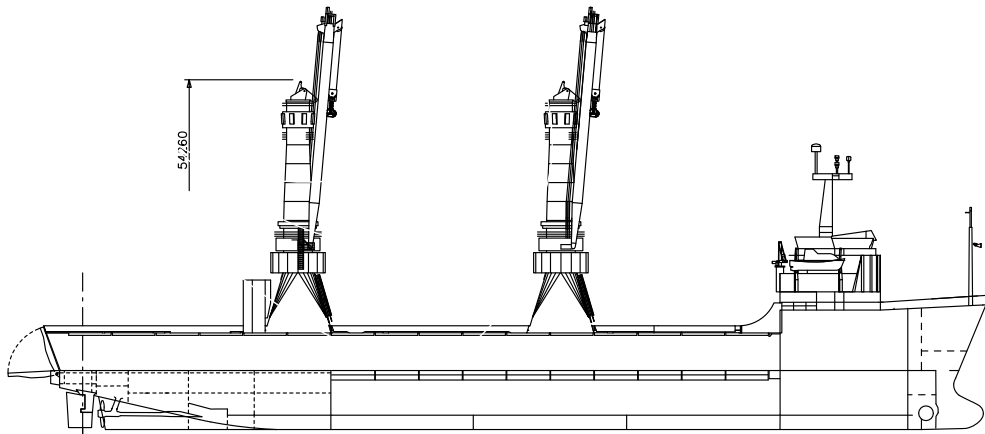

SIDEVIEW

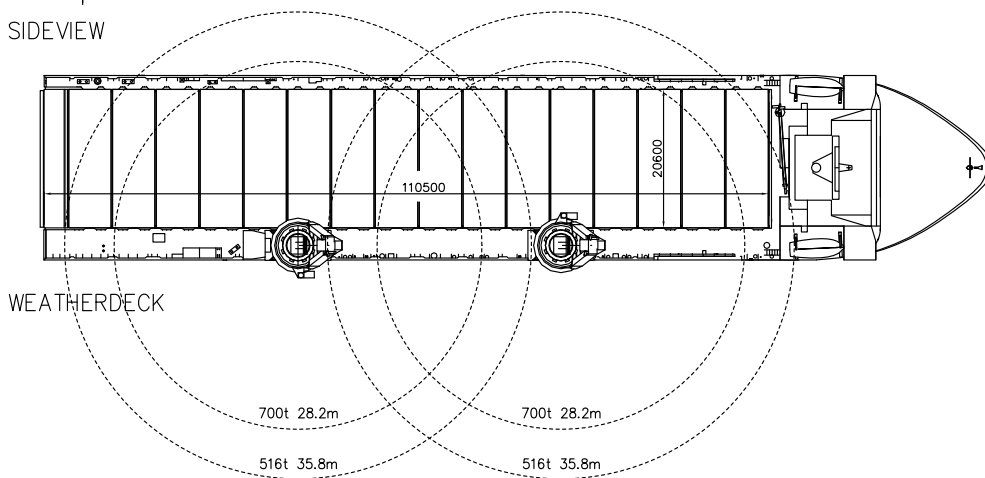

WEATHERDECK

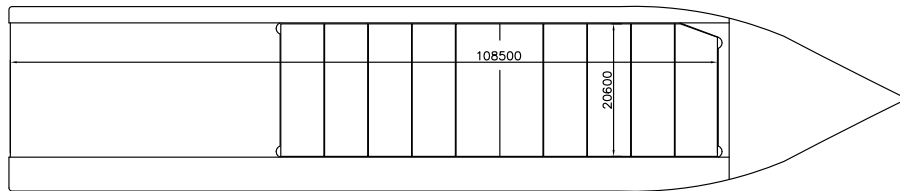

TWEENDECK

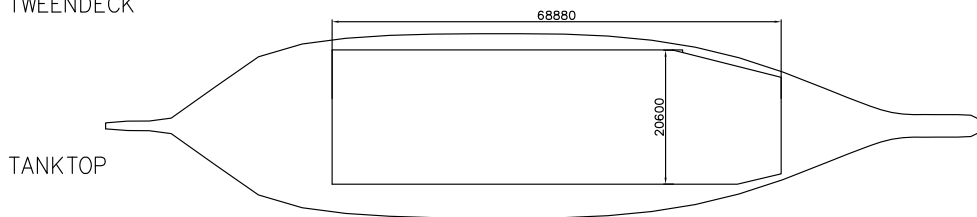

TANKTOP

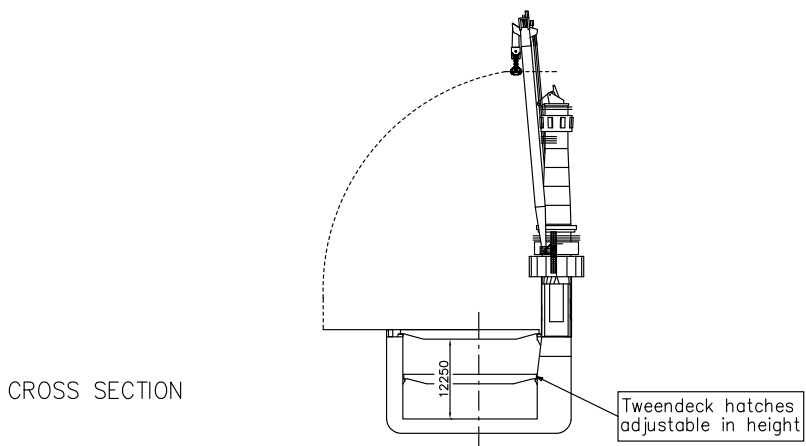

CROSS SECTION

HAPPY BUCCANEER

Class		LRS X 100A1 X LMC UMS			
Principal Dimensions	Length overall	145.89	m		
	Length p.p.	134.00	m		
	Breadth moulded	28.30	m		
	Summer draft	8.24	m		
	Draft "open sailing"	7.02	m		
Deadweight	Summer (sea water)	13,740	mton		
Tonnage		International	Panama	Suez	
	GT	16,341.00	16,352	16,081.43	
	NT	4,902.00	13,473	12,642.02	
Capacity	Lowerhold	7,517	m ³		
	Tween deck	12,391	m ³		
Floor space	Weather deck	3,067	m ²		
	Tween deck	2,275	m ²		
	Tank top	1,344	m ²		
Hatch openings	Weather deck	110.5 x 20.6	m		
	Tween deck	67.0 x 20.0	m		
Heights	Tween deck	5.38	m		
	Lower hold	5.42	m		
	Total hold	12.25	m		
Allowable loads	Weather deck hatch covers	5.0	t/m ²		
	with pillars	15.0	t/m ²		
	Tween deck hatch covers	5.0	t/m ²		
	with pillars	15.0	t/m ²		
	Tank top	15.0	t/m ²		
Cranes	Combinable	1400	mt	SWL	
	Situated on starboard side	2 x 700	mt	SWL	
	Fitted with trolley				
	Trolley capacity	2 x 25	mt	SWL	
Ramp	Position	stern			
	Dimensions	20.3 x 7.6	m		
	Capacity	2,500	mton		
	Working height	2 - 3.5	m		
Main engine	2 x Hitachi Sulzer 6ZAL 40	2x 3840	kW		
	Bowthruster	760	kW		
	Service speed	14.75	kn	at draft 6.00 m	
Container capacity		1050	TEU		

HAPPY BUCCANEER

Happy Buccaneer Amsterdam The Netherlands 1984

These particulars are believed to be correct, but without guarantee, and they must not be used as basis for Charter Parties or contracts without Owners' explicit written authority.



Radarweg 36
1042 AA Amsterdam

P.O. Box 2599
1000 CN Amsterdam

t. +31 (0) 20 - 448 83 00
f. +31 (0) 20 - 448 83 33

info@bigliftshipping.com
www.bigliftshipping.com